











- 1 
- 2 
- 3 
- 4 
- 5 
- 6 
- 7 
- 8 
- 9 
- 10 
- 11 
- 12 
- 13 
- 14 
- 15 
- 16 
- 17 
- 18 
- 19 

**VERSIONS**

- Type **C1**: chamfer, top
- Type **C2**: chamfer, bottom
- Type **C3**: chamfer, right
- Type **C4**: chamfer, left
- Type **CU**: unmounted

**GUIDE**

- Steel precision casting **ST**
- Weldable, blackened
- Stainless steel precision casting AISI CF-8 **NI**
- Weldable

**LIFTING RING**

- Steel precision casting
- Zinc plated, blue passivated (for **ST**)
- Stainless steel precision casting AISI CF-8 (for **NI**)

**PLUNGER**

- Steel, case-hardened
- Zinc plated, blue passivated **ST**
- Stainless steel AISI 431, hardened **NI**

**SOCKET BUTTON HEAD SCREW DIN 7985**

- Zinc-plated steel **ST**
- Stainless Steel AISI 304 **NI**

**SPRING**

AISI 316Ti stainless Steel

**FEATURES AND APPLICATIONS**

Indexing plungers GN 724.4 have a plunger pin with square cross-section, a latching surface on one side and a chamfer on the other. When the object to be secured moves towards the chamfer, the plunger pin is pushed back into the guide, allowing grooves and edges to pass over the pin. The plunger pin engages automatically in the direction of the latching surface.

The latching can be released by pulling the pull ring by hand or with a cable or pull rod using a hook. The types with rest position are used when the plunger pin should temporarily not protrude. For this purpose, the pull ring is turned sideways after the plunger pin has been retracted. The ring is held in this position by the catch recess at the top of the guide.

The dimensional tolerances between plunger pin and guide are selected so that the functional reliability is guaranteed even after welding, applying a corrosion protection layer or in case of contamination.

For fastening by welding, the unmounted type CU is particularly recommended to avoid changes to the microstructure of the material due to heating of the spring and plunger pin.



Assembly instruction  
GN 724.4-CU

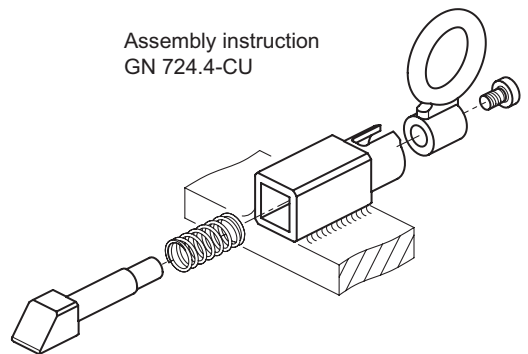

GN 724.4-C1

GN 724.4-C2

GN 724.4-C3

GN 724.4-C4

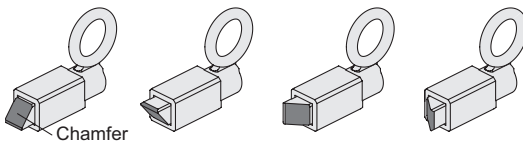

Indexing and positioning elements

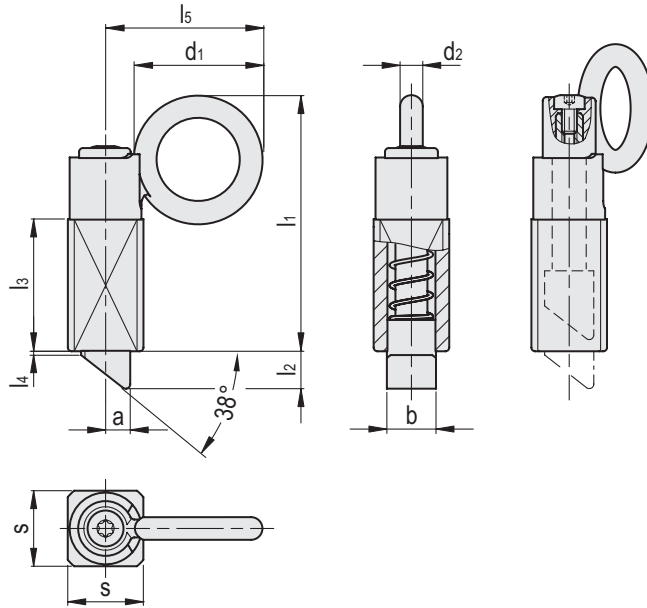

Conversion Table	
1 mm = 0.039 inch	
b	
mm	inch
13	0.51
20	0.78

GN 724.4-C1-ST

METRIC

Code	Description	d1	d2	a	b	l1	l2	l3	l4	l5	s	Spring preload [N]	Spring max load [N]	⚖
GN.78702	GN 724.4-13-20-C1-ST	34	6	6.5	13	68	10	35	1	41.5	20	14	35	149
GN.78716	GN 724.4-20-30-C1-ST	48	9	10	20	102	15	54	1.5	60	30	22	70	515

GN 724.4-C2-ST

Code	Description	d1	d2	a	b	l1	l2	l3	l4	l5	s	Spring preload [N]	Spring max load [N]	⚖
GN.78704	GN 724.4-13-20-C2-ST	34	6	6.5	13	68	10	35	1	41.5	20	14	35	149
GN.78718	GN 724.4-20-30-C2-ST	48	9	10	20	102	15	54	1.5	60	30	22	70	515

GN 724.4-C3-ST

Code	Description	d1	d2	a	b	l1	l2	l3	l4	l5	s	Spring preload [N]	Spring max load [N]	⚖
GN.78706	GN 724.4-13-20-C3-ST	34	6	6.5	13	68	10	35	1	41.5	20	14	35	149
GN.78720	GN 724.4-20-30-C3-ST	48	9	10	20	102	15	54	1.5	60	30	22	70	515

GN 724.4-C4-ST

Code	Description	d1	d2	a	b	l1	l2	l3	l4	l5	s	Spring preload [N]	Spring max load [N]	⚖
GN.78708	GN 724.4-13-20-C4-ST	34	6	6.5	13	68	10	35	1	41.5	20	14	35	149
GN.78722	GN 724.4-20-30-C4-ST	48	9	10	20	102	15	54	1.5	60	30	22	70	515

GN 724.4-CU-ST

Code	Description	d1	d2	a	b	l1	l2	l3	l4	l5	s	Spring preload [N]	Spring max load [N]	⚖
GN.78710	GN 724.4-13-20-CU-ST	34	6	6.5	13	68	10	35	1	41.5	20	14	35	149
GN.78724	GN 724.4-20-30-CU-ST	48	9	10	20	102	15	54	1.5	60	30	22	70	515



Indexing and positioning elements

- 1
- 2
- 3
- 4
- 5
- 6
- 7
- 8
- 9
- 10
- 11
- 12
- 13
- 14
- 15
- 16
- 17
- 18
- 19

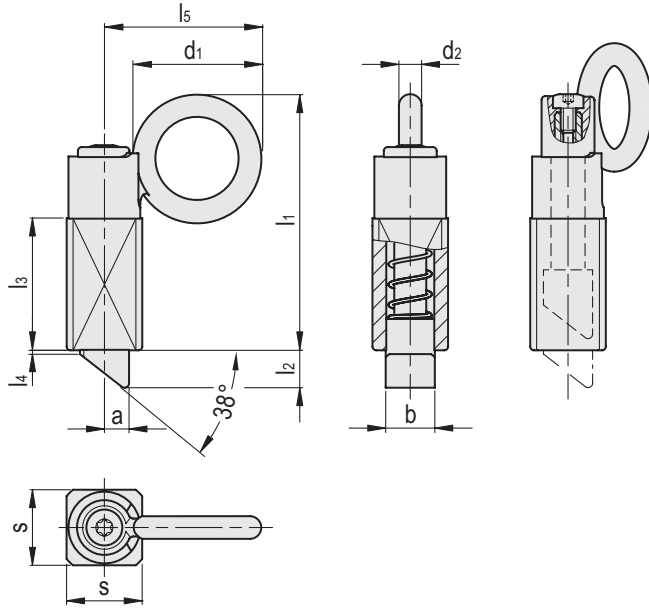

Conversion Table	
1 mm = 0.039 inch	
b	
mm	inch
13	0.51
20	0.78

**INOX** STAINLESS STEEL **METRIC**

**GN 724.4-C1-NI**

Code	Description	d1	d2	a	b	l1	l2	l3	l4	l5	s	Spring preload [N]	Spring max load [N]	⚖️
GN.78701	GN 724.4-13-20-C1-NI	34	6	6.5	13	68	10	35	1	41.5	20	14	35	149
GN.78715	GN 724.4-20-30-C1-NI	48	9	10	20	102	15	54	1.5	60	30	22	70	518

**GN 724.4-C2-NI**

Code	Description	d1	d2	a	b	l1	l2	l3	l4	l5	s	Spring preload [N]	Spring max load [N]	⚖️
GN.78703	GN 724.4-13-20-C2-NI	34	6	6.5	13	68	10	35	1	41.5	20	14	35	149
GN.78717	GN 724.4-20-30-C2-NI	48	9	10	20	102	15	54	1.5	60	30	22	70	518

**GN 724.4-C3-NI**

Code	Description	d1	d2	a	b	l1	l2	l3	l4	l5	s	Spring preload [N]	Spring max load [N]	⚖️
GN.78705	GN 724.4-13-20-C3-NI	34	6	6.5	13	68	10	35	1	41.5	20	14	35	149
GN.78719	GN 724.4-20-30-C3-NI	48	9	10	20	102	15	54	1.5	60	30	22	70	518

**GN 724.4-C4-NI**

Code	Description	d1	d2	a	b	l1	l2	l3	l4	l5	s	Spring preload [N]	Spring max load [N]	⚖️
GN.78707	GN 724.4-13-20-C4-NI	34	6	6.5	13	68	10	35	1	41.5	20	14	35	149
GN.78721	GN 724.4-20-30-C4-NI	48	9	10	20	102	15	54	1.5	60	30	22	70	518

**GN 724.3-CU-NI**

Code	Description	d1	d2	a	b	l1	l2	l3	l4	l5	s	Spring preload [N]	Spring max load [N]	⚖️
GN.78709	GN 724.4-13-20-CU-NI	34	6	6.5	13	68	10	35	1	41.5	20	14	35	149
GN.78723	GN 724.4-20-30-CU-NI	48	9	10	20	102	15	54	1.5	60	30	22	70	518

Indexing and positioning elements